

RELN 3200L HOLDING TANK

Installation Instructions



50 years of Innovation

Excavation

1. Excavate site for installing tank in ground as per building code and local authority requirements. Ensure adequate pipe fall from the septic tank outlet to the holding tank. Additionally, holding tanks are to be sited:
 - away from building foundations,
 - away from traffic areas, both vehicular and pedestrian,
 - away from or fenced off from animal stock pastures and areas.
2. Refer to the tank dimensions for correct levels.
3. Do not bury tank lid. Manhole Cover and Inspection Covers must be finished above normal ground level to allow ongoing tank inspection and maintenance.
4. In excavation prepare a level 50mm bed of compacted sand or soft fill free of large and/or sharp objects.
5. Carefully lower tank base into excavation - do not drop
6. Align inlet and outlet with pipe trenches
7. Ensure tank base is level - level with lid off

Tank Base Assembly

1. On inlet side of tank base fit Inlet T-Junction. Apply silicone sealer to the flange of the T-Junction and secure with supplied four (4) stainless steel self tapping screws.

Pipe Connection

1. Connect 100mm PVC sewer pipe into Inlet T-Junction. Glue inlet pipe to T-Junction with PVC plumbers glue.

Tank Anchoring

1. Tie anchoring ropes (8) to the pre-drilled lugs in the rim of the tank. Leave the looped end to hang free.
2. Place four durable anchoring beams (not included) through the looped ends of the ropes.
3. Anchor beams can be made from 100mm PVC sewer pipe and should be 2 metres long and positioned to exceed the tank's extremities.

Lid Installation

1. Apply a sealing bead of silicone in the top lip of the tank base.
2. Place lid onto tank base. A dowel pin adjacent to the inlet side aligns the lid and base.
3. Drill and fix lid in position with eight (8) provided stainless steel bolts screws and washers.
4. Apply a sealing bead of silicone to lid recess for Manhole Cover.
5. Secure manhole cover in position with six (6) stainless steel self tapping screws provided.
6. Fill tank with water. Manhole Cover must be secured before filling.
7. Apply a sealing bead of silicone to lid and secure the two inspection covers.

Discharge Pipe

1. Discharge pipe by plumber. Ensure discharge pipe hole does not cut through strengthening ribs. Fasten discharge pipe to lid using 316 Stainless Steel screws. Seal discharge pipe to lid with silicone.
2. Ensure maximum length of discharge pipe is half of tank depth.
3. Holding tanks must only be pumped out half way.
4. Discharge pipe connections to be positioned for easy pump-out vehicle access.

Completion

1. After filling tank with water, backfill around tank with clean filling and compact thoroughly. **Important - no large or sharp objects in backfill material.**
2. Ensure surface water run-off is directed away from pipe trenches and tank installation.

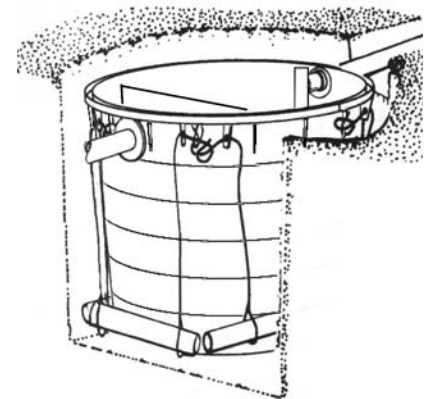

Installation

Product Components

Reln Plastic Holding Tanks are approved under the requirements of the Australian Standard AS/NZS1546.1:1998, licence number 1651. Reln Holding Tanks are to be installed as per these instructions and local authority requirements by a licenced plumber. The Reln Holding Tank is supplied including the following components:

Item No	Qty	Description
1	1	Tank Base - factory predrilled to nominal capacity of 3200L
2	1	Tank Lid
3	1	Manhole Cover
4	2	Inspection Cover
Accessory Kit Contents		
5	1	Inlet T-Junction
8	6	Manhole Self Tapping Screws, 10g 316 Stainless Steel
9	8	T-Junction Self Tapping Screws, 10g 316 Stainless Steel
10	8	Lid Bolt, Washer, Nut, M6 316 Stainless Steel
11	2	Baffle Bolt, Washer, Nut, M6 316 Stainless Steel
12	8	Anchor Rope
13	1	Installation Instructions

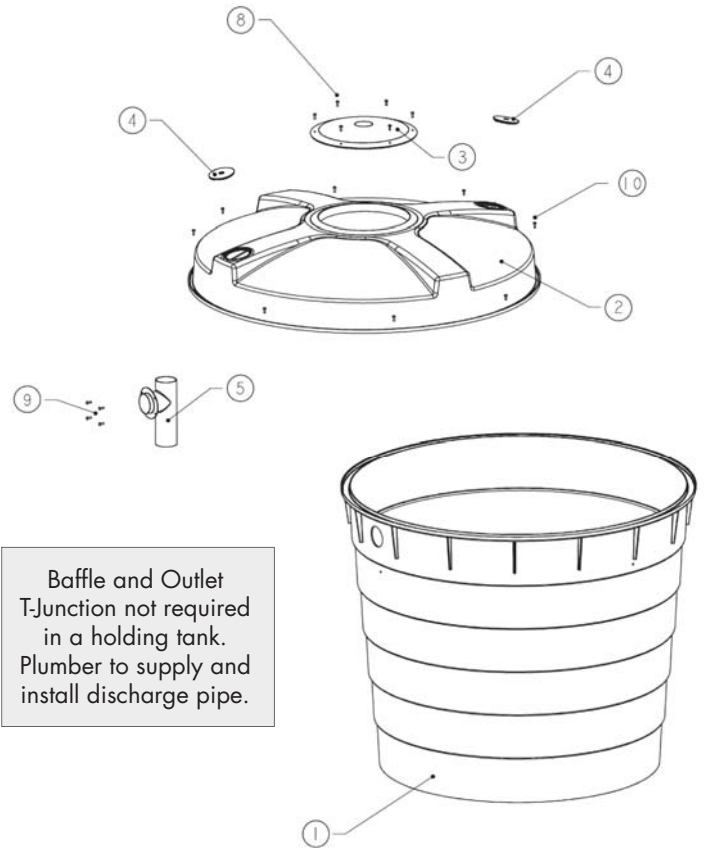

Holding Tank Nominal Dimensions		
A	Overall Tank Height (mm)	2038
B	Liquid Depth Level (mm)	1427
C	Tank Rim to Invert of Outlet (mm)	200
D	Under Roof to Liquid Level (mm)	460
E	Maximum Cover to Inlet Pipe (mm)	300
G	Overall Diameter (mm)	1998
H	Tank Base to Ground Level (mm)	1887
Capacity (litres)		3200
Weight (kg)		122

